

Flyback PWM Controller with Integrated Active Clamp Circuit

Features

- Integrated UHV Active Clamp FET, Active Clamp Driver and Start-up Regulator
- Capable of Over 93.5% Efficiency
- Flat Efficiency Across Universal (90 - 265 Vac) Input Voltage and Load
- Tight Switching Frequency Regulation for Improved Input EMI Filter Utilization
- Up to 140 kHz Switching Frequency Operation
- OptiMode™ Cycle-by-Cycle Adaptive Digital Control
- Quasi-Resonant (QR), Valley Mode Switching (VMS) for low EMI
- Multi-Mode Operation (Burst Mode, QR, VMS)
- QR Valley Mode Switching for low EMI
- Self-Tuning Valley Detection
- OTP, OVP, OCP, OOPP and OSCP Protections
- <50 mW No Load Power Consumption
- Up to 33 W Output Power
- 16-pin SOIC Package

Applications

- High Power Density USB-PD AC/DC Power Supplies
- High Efficiency USB-PD Power Adapters

Application Diagram

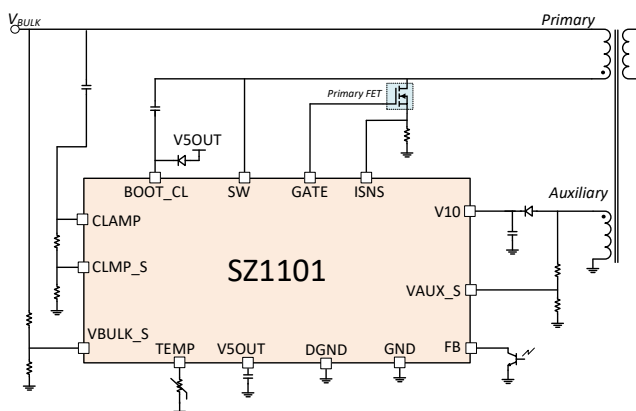

Figure 1: Active Clamp Flyback Controller

Product Description

The SZ1101 is an Active Clamp Flyback (ACF) PWM Controller that integrates an adaptive digital PWM controller and the following Ultra High-Voltage (UHV) components: active clamp FET, active clamp driver and a start-up regulator.

The device provides ease-of-design of a simple flyback controller with all the benefits of an ACF design, including recycling of the leakage inductance energy of the flyback transformer and limiting the primary FET drain voltage spike during the turn-off events. Employing Silanna's OptiMode™ digital control architecture, the SZ1101 adjusts the device's mode of operation on a cycle-by-cycle basis to maintain high efficiency, low EMI, fast dynamic load regulation and other key power supply parameters in response to varying line voltage and load.

Furthermore, the switching frequency is confined within a tight frequency band for simplified EMI filtering. In addition, adaptive digital control of active clamp operation enables near ZVS turn-on of the primary FET and clamps the drain voltage during the turn-off, thus further improving efficiency and reducing EMI.

Unlike conventional ACF designs, tight tolerances of the clamp capacitor and leakage inductance values are not required for proper operation of the circuit in high volume production. Moreover, a small 3.3 nF clamp capacitor is sufficient to realize the benefits of ACF operation. The SZ1101 is well suited for high efficiency and high-power density USB-PD AC/DC power adapters, providing up to 33 W output power.

The SZ1101 is available in a space saving 16-pin SOIC package.

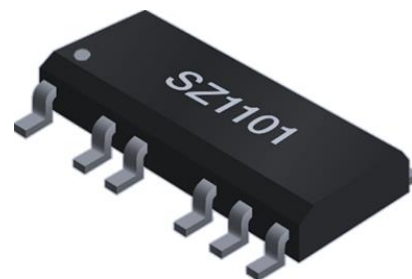

Figure 2: Device Package Image

Pinout

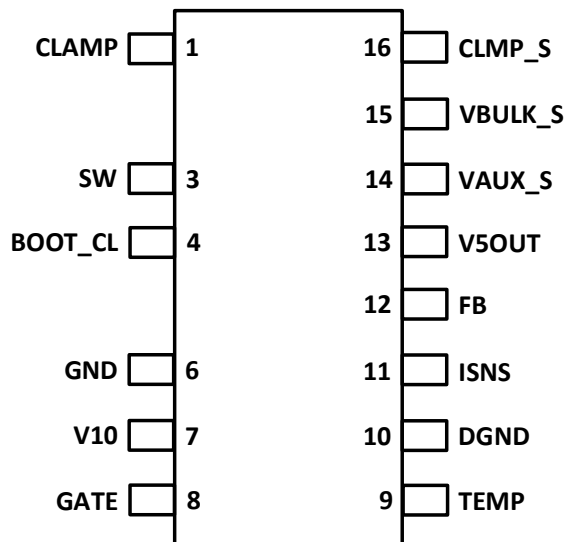

Figure 3. SZ1101, SOIC16-2L, 1.27 mm Pitch Package Pinout – Device Top View

Pin Descriptions

Pin #	Name	Voltage Category (Vdc)	Description
1	CLAMP	UHV (620V)	Drain of Active Clamp (ACL) FET. Connect through a clamp capacitor to VBULK
3	SW	UHV (620V)	Switching node. Connect to transformer primary and Drain of the Primary N-FET
4	BOOT_CL	UHV (620V)	Bootstrap supply input for internal ACL FET driver. Connect a bootstrap diode from V5OUT to BOOT_CL and a bootstrap capacitor from SW node
6	GND	LV (0)	Power ground pin for the IC. Connect to GND
7	V10	LV (10V)	Supply voltage input, 9.5 V nominal
8	GATE	LV (10V)	Gate driver output for Primary N-FET (refer to V10)
9	TEMP	LV (5V)	External NTC temperature sensor input
10	DGND	LV (0)	Digital ground. Connect to GND
11	ISNS	LV (5V)	Current sense input. Connect to the positive terminal of the current shunt resistor
12	FB	LV (5V)	Output voltage error input (feedback). Connect to the Optocoupler collector and pull up to V5OUT
13	V5OUT	LV (5V)	Output and decoupling pin for the internal +5 V supply
14	VAUX_S	LV: (5V)	Auxiliary winding sense input for QR operation. Connect the auxiliary positive terminal to this pin via a resistor divider
15	VBULK_S	LV: (5V)	VBULK sense input. Connect to the rectified input voltage (VBULK) via a resistor divider
16	CLMP_S	LV: (5V)	Active Clamp sense input. Connect to CLAMP via a resistive divider

Typical Application Circuit

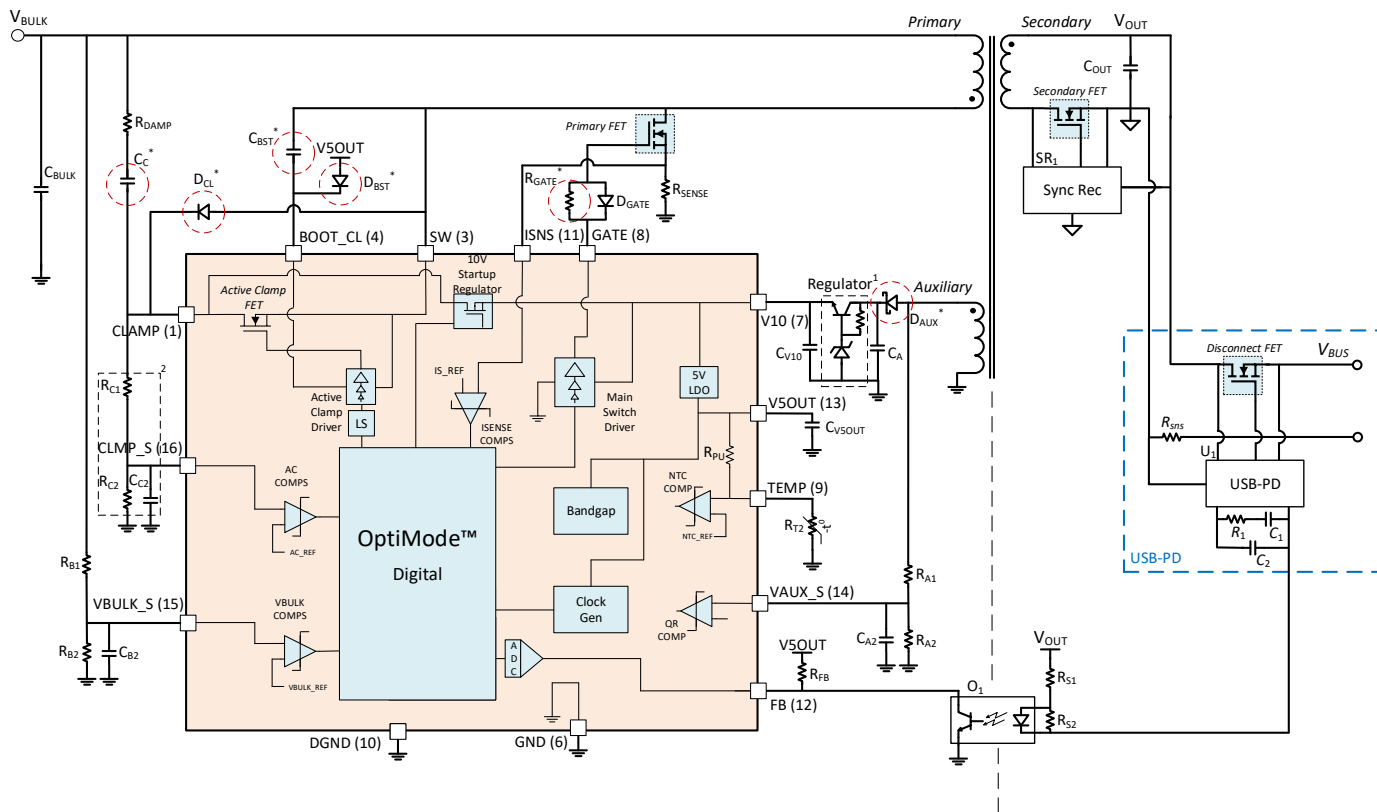

Figure 4. Typical Application Circuit of an USB-PD Active Clamp Flyback Converter using SZ1101

Notes:

- * Critical components are identified with red dotted circles. Careful considerations are required when selecting these components for reliable operation of the device.
- 1. The discrete regulator is required as the output voltage varies over a wide range in USB-PD applications (5-20 V).
- 2. Removing R_{C1} and R_{C2} resistors and connecting CLMP_S pin to V5OUT pin results in conducted EMI suppression above 2 MHz with a minimal efficiency penalty (~0.1%).

Product Ordering Information ^{Note 1}

Part Number	Package	Feature	Shipping Method
SZ1101-02	16-pin SOIC	Hiccup Mode Fault Protection (OTP Latched)	5,000 pcs Tape & Reel
SZ1101-03	16-pin SOIC	Latched Mode Fault Protection (UVLO Auto-Recovery)	5,000 pcs Tape & Reel

Note:

- 1) 16-pin package with two pins removed.

Package Dimensions

COMMON DIMENSION			
SYMBOL	MINIMUM	NOMINAL	MAXIMUM
A	-	-	1.75
A1	0.10	-	0.25
A2	1.30	-	1.50
b	0.33	-	0.51
b1	0.21	-	0.48
c	0.19	-	0.25
c1	0.10	-	0.23
D	9.80	-	10.01
E	5.80	-	6.20
E1	3.84	-	3.99
e	1.27 BSC		
e1	2.54 BSC		
L	0.51	-	0.76
L1	1.05 REF		
θ	0 degree	-	8 degree
θ1	7 degree REF		
aaa	0.10		
bbb	0.20		
eee	0.10		
N	14 (16-2)		

- NOTE:
1. DIMENSIONING AND TOLERANCING PER ASME Y14.5M-1994
 2. DIMENSIONS IN MILLIMETERS (ANGLES IN DEGREES)
 3. DIMENSION D DOES NOT INCLUDE MOLD FLASH, PROTRUSIONS OR GATE BURRS. MOLD FLASH, PROTRUSIONS OR GATE BURRS SHALL NOT EXCEED 0.15mm PER END. D AND E1 DIMENSIONS ARE DETERMINED AT DATUM H.
 4. THE PACKAGE TOP MAY BE SMALLER THAN THE PACKAGE BOTTOM. DIMENSION D AND E1 ARE DETERMINED AT THE OUTERMOST EXTREMES OF THE PLASTIC BODY EXCLUSIVE OF MOLD FLASH, TIE BURRS, GATE BURRS AND INTERLEAD FLASH, BUT INCLUDING ANY MISMATCH BETWEEN THE TOP AND BOTTOM OF THE PLASTIC BODY.
 5. DATUMS A & B TO BE DETERMINED AT DATUM H.
 6. THE DIMENSIONS APPLY TO THE FLAT SECTION OF THE LEAD BETWEEN 0.10 TO 0.25mm FROM THE LEAD TIP.
 7. THE CHAMFER FEATURE IS OPTIONAL. IF IT IS NOT PRESENT, THEN A PIN 1 IDENTIFIER MUST BE LOCATED WITHIN THE INDEX AREA INDICATED
 8. DIMENSION "b" DOES NOT INCLUDE THE DAMBAR PROTUSION. THE DAMBAR MAY NOT BE LOCATED ON THE LOWER RADIUS OF THE FOOT.

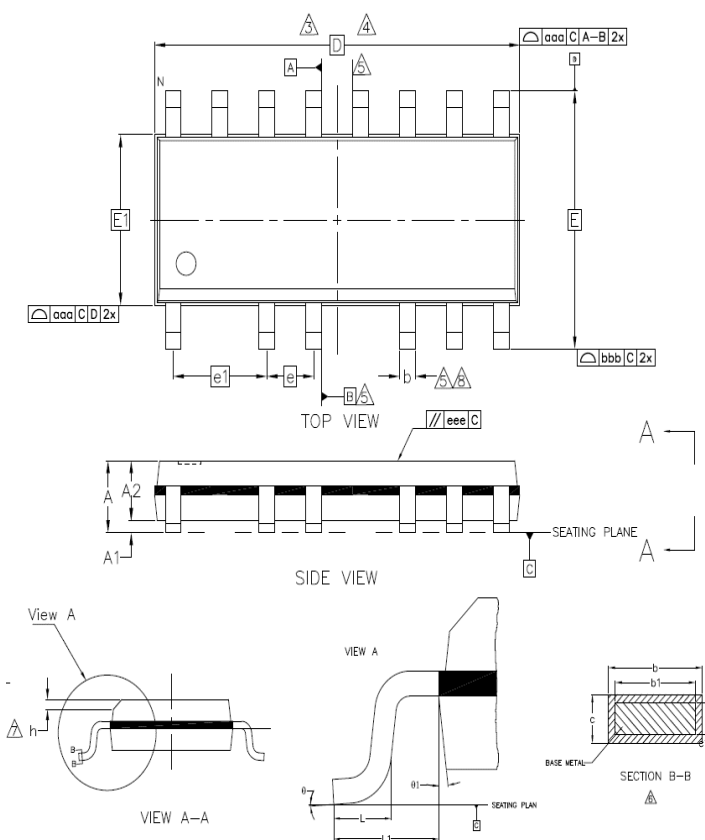

Figure 5: Package Dimensions



Silanna Semiconductor Proprietary and Confidential

Information furnished by Silanna Semiconductor is believed to be accurate and reliable. However, no responsibility is assumed for its use. Silanna Semiconductor makes no representation that the interconnection of its circuits as described herein will not infringe on existing patents rights.

4795 Eastgate Mall, Suite 100, San Diego, CA 92121
 Toll Free: (888) 637-3564 | Fax: (858) 373-0437 | www.powerdensity.com