

Flyback PWM Controller with Integrated Active Clamp Circuit

Features

- Integrated UHV Active Clamp FET, Active Clamp Driver, and Start-up Regulator
- Capable of Over 95% Efficiency
- Flat Efficiency Across Universal (90 - 265 Vac) Input Voltage and Load
- < 20 mW System No Load Power Consumption
- Up to 146 kHz Switching Frequency Operation
- OptiMode™ Cycle-by-Cycle Adaptive Digital Control
- Self-tuning Valley Mode Switching (VMS)
- Advanced QR VMS for > 6 dB EMI Margin
- Tight Switching Frequency Regulation for Improved Input EMI Filter Utilization
- Multi-Mode Operation (Burst Mode, QR, VMS)
- OTP, OVP, OCP, OPP, OSCP, TSP Protections
- Up to 65 W Output Power for Universal AC Input
- 100W+ Output Power with Front-End PFC
- 16-pin SOIC Package

Applications

- High Power Density AC/DC Power Supplies
- High Efficiency Power Adapters
- USB-PD/QC AC/DC Power Adapters
- Battery Chargers for Mobile Devices

Application Diagram

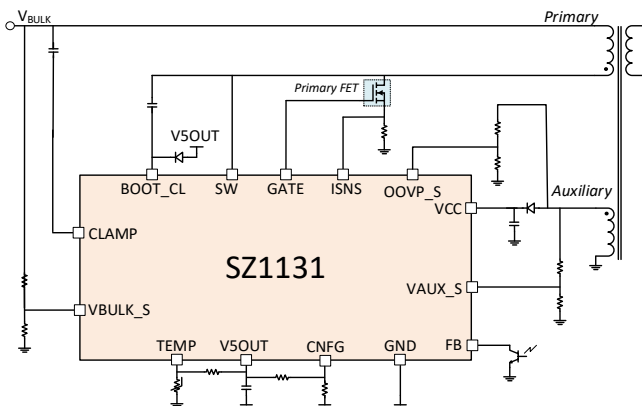

Figure 1: Active Clamp Flyback Controller

Product Description

The SZ1131 is an Active Clamp Flyback (ACF) PWM Controller that integrates an adaptive digital PWM controller and the following Ultra High-Voltage (UHV) components: active clamp FET, active clamp driver and a start-up regulator.

The device provides the ease-of-design of a simple flyback controller with all the benefits of an ACF design, including recycling of the leakage inductance energy of the flyback transformer and limiting the primary FET drain voltage spike during the turn-off events. Employing Silanna's OptiMode™ digital control architecture, the SZ1131 adjusts its mode of operation on a cycle-by-cycle basis to maintain high efficiency, low EMI, fast dynamic load regulation and other key power supply parameters in response to varying line voltage and load.

Furthermore, the switching frequency is confined within a tight frequency band for simplified EMI filtering. In addition, adaptive digital control of the active clamp operation enables near ZVS turn-on of the primary FET and clamps the drain voltage during the turn-off, further improving efficiency and reducing EMI.

Unlike conventional ACF designs, tight tolerances of the clamp capacitor and leakage inductance values are not required for proper operation of the circuit in high volume production. The SZ1131 is well suited for high efficiency and high-power density AC/DC power adapters. The device is designed for up to 65 W output power for universal AC input and 100W+ output power with front-end PFC support, including USB-PD and PPS applications.

The SZ1131 is available in a space saving 16-pin SOIC package.



Figure 2: Device Package Image

Pin Out

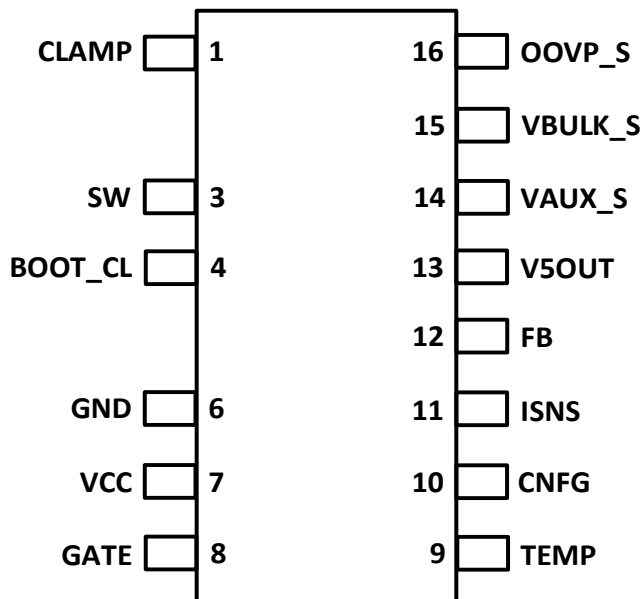

Figure 3: SZ1131, SOIC16, 1.27 mm Pitch Package Pinout – Device Top View

Pin Definitions

Pin #	Name	Voltage Category (Vdc)	Description
1	CLAMP	UHV (620V)	Drain of Active Clamp (ACL) FET. Connect through a clamp capacitor to VBULK
3	SW	UHV (620V)	Switching node. Connect to transformer primary and Drain of the Primary N-FET
4	BOOT_CL	UHV (620V)	Bootstrap supply input for internal ACL FET driver. Connect a bootstrap diode from V5OUT to BOOT_CL and a bootstrap capacitor from SW node
6	GND	LV (0)	Power ground pin for the IC. Connect to GND
7	VCC	LV (15V)	Supply voltage input
8	GATE	LV (15V)	Gate driver output for Primary N-FET (refer to VCC)
9	TEMP	LV (5V)	External NTC temperature sensor input
10	CNFG	LV (5V)	Configuration pin. Connect to V5OUT via a resistor divider
11	ISNS	LV (5V)	Current sense input. Connect to the positive terminal of the current shunt resistor
12	FB	LV (5V)	Output voltage error input (feedback). Connect to the Optocoupler collector and pull up to V5OUT
13	V5OUT	LV (5V)	Output and decoupling pin for the internal +5 V supply
14	VAUX_S	LV: (8V)	Auxiliary winding sense input for QR operation. Connect the auxiliary positive terminal to this pin via a resistor divider
15	VBULK_S	LV: (5V)	VBULK sense input. Connect to the rectified input voltage (VBULK) via a resistor divider
16	OOVP_S	LV: (8V)	Output over-voltage sense input. Connect the auxiliary positive terminal to this pin via a resistor divider

Typical Application Circuit (Preliminary: Subject to Change)

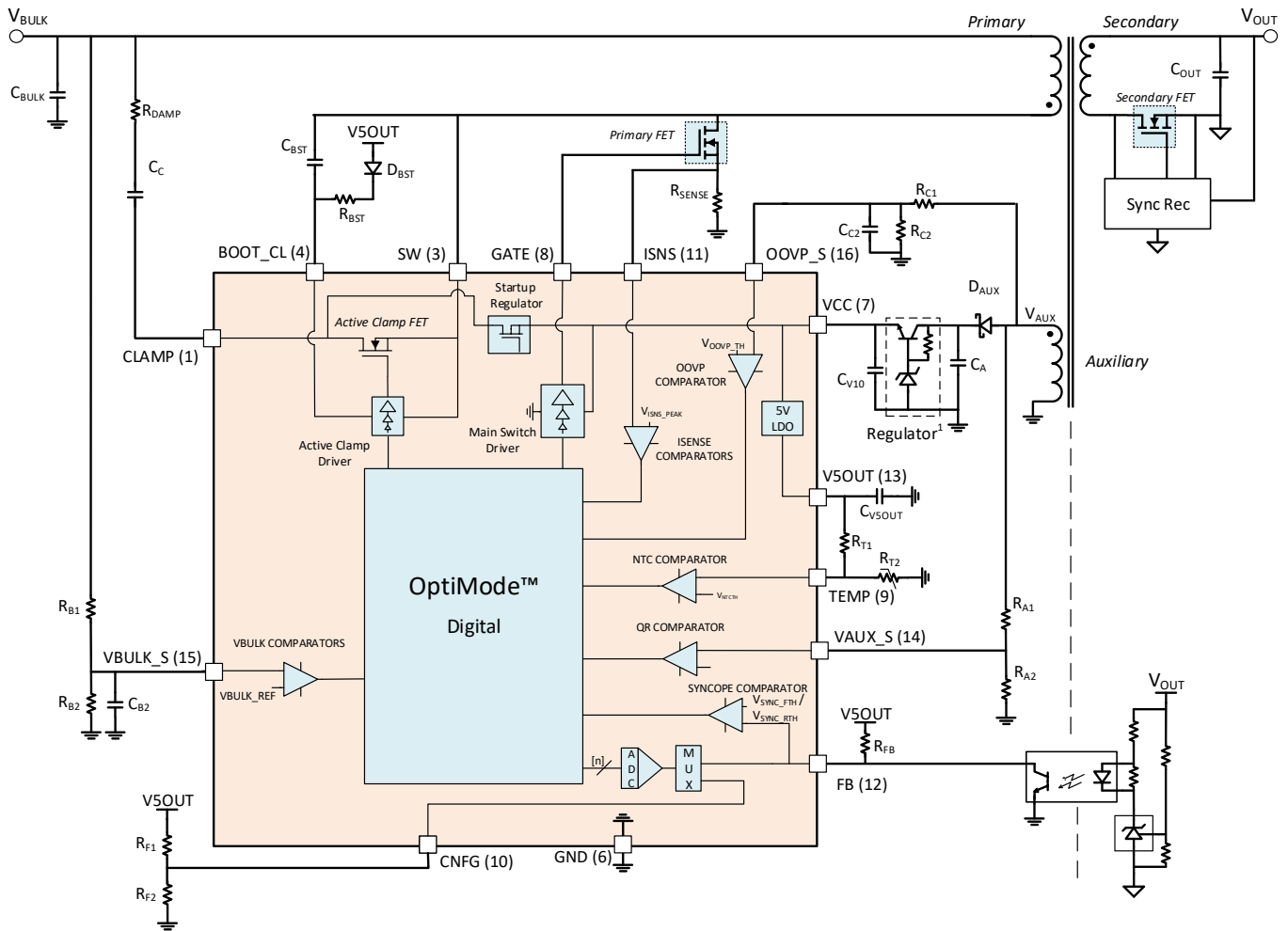

Figure 4: Typical Application Circuit of an Active Clamp Flyback Converter using SZ1131

Notes:

1. The discrete regulator is required for applications where the output voltage varies over a wide range, such as USB-PD (5 V - 20 V) and Quick Charge (5 V - 20 V); may not be required for fixed output voltage applications.

Product Ordering Information ^{Note 1}

Part Number	Package	Feature	Shipping Method
SZ1131-00	16-pin SOIC	Flyback PWM Controller with Integrated Active Clamp Circuit	2,500 pcs Tape & Reel

Note:

- 1) 16-pin package with two pins removed.

Package Dimensions

COMMON DIMENSION			
SYMBOL	MINIMUM	NOMINAL	MAXIMUM
A	-	-	1.75
A1	0.10	-	0.25
A2	1.30	-	1.50
b	0.33	-	0.51
b1	0.21	-	0.48
c	0.19	-	0.25
c1	0.10	-	0.23
D	9.80	-	10.01
E	5.80	-	6.20
E1	3.84	-	3.99
e	1.27 BSC		
e1	2.54 BSC		
L	0.51	-	0.76
L1	1.05 REF		
θ	0 degree	-	8 degree
θ1	7 degree REF		
aaa	0.10		
bbb	0.20		
eee	0.10		
N	14 (16-2)		

- NOTE:
1. DIMENSIONING AND TOLERANCING PER ASME Y14.5M-1994
 2. DIMENSIONS IN MILLIMETERS (ANGLES IN DEGREES)
 3. DIMENSION D DOES NOT INCLUDE MOLD FLASH, PROTRUSIONS OR GATE BURRS. MOLD FLASH, PROTRUSIONS OR GATE BURRS SHALL NOT EXCEED 0.15mm PER END. D AND E1 DIMENSIONS ARE DETERMINED AT DATUM H.
 4. THE PACKAGE TOP MAY BE SMALLER THAN THE PACKAGE BOTTOM. DIMENSION D AND E1 ARE DETERMINED AT THE OUTERMOST EXTREMES OF THE PLASTIC BODY EXCLUSIVE OF MOLD FLASH, TIE BURRS, GATE BURRS AND INTERLEAD FLASH, BUT INCLUDING ANY MISMATCH BETWEEN THE TOP AND BOTTOM OF THE PLASTIC BODY.
 5. DATUMS A & B TO BE DETERMINED AT DATUM H.
 6. THE DIMENSIONS APPLY TO THE FLAT SECTION OF THE LEAD BETWEEN 0.10 TO 0.25mm FROM THE LEAD TIP.
 7. THE CHAMFER FEATURE IS OPTIONAL. IF IT IS NOT PRESENT, THEN A PIN 1 IDENTIFIER MUST BE LOCATED WITHIN THE INDEX AREA INDICATED
 8. DIMENSION "b" DOES NOT INCLUDE THE DAMBAR PROTUSION. THE DAMBAR MAY NOT BE LOCATED ON THE LOWER RADIUS OF THE FOOT.

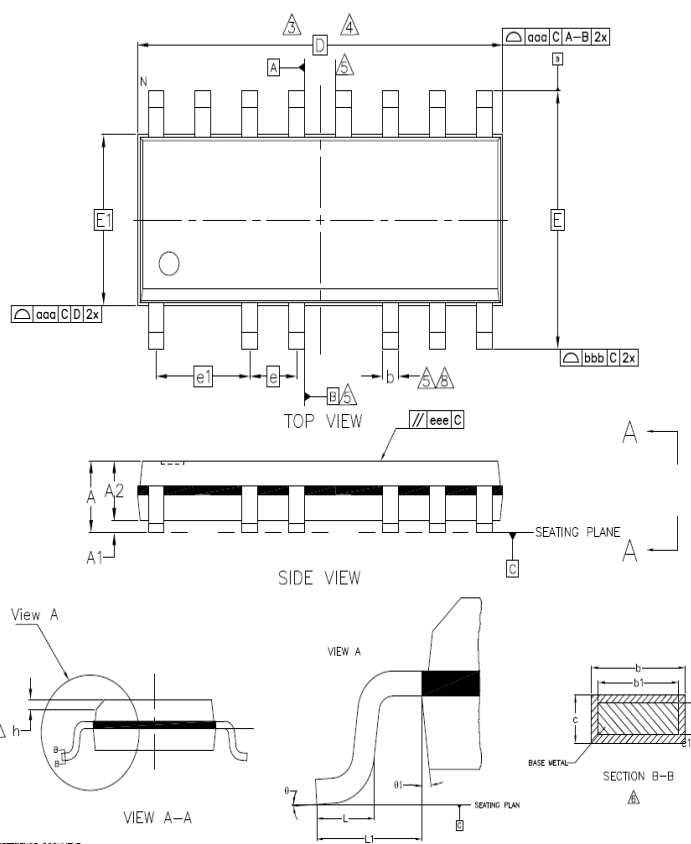

Figure 5: Package Dimensions

Silanna Semiconductor Proprietary and Confidential

Information furnished by Silanna Semiconductor is believed to be accurate and reliable. However, no responsibility is assumed for its use. Silanna Semiconductor makes no representation that the interconnection of its circuits as described herein will not infringe on existing patents rights.

4795 Eastgate Mall, Suite 100, San Diego, CA 92121
 Toll Free: (888) 637-3564 | Fax: (858) 373-0437 | www.powerdensity.com